



**HARDWARE INSTALLATION**

New System Setup..... 2  
 Customer Supplied Hardware..... 3  
 Cabinet Mounting & Alignment ..... 4  
 Mounting System ..... 5  
 Key Panels ..... 6

**POWER AND NETWORK SET UP**

System Power ..... 7  
 Establishing Communications ..... 8  
 Connecting Using Wireless Connection ..... 9

**INITIAL SETUP**

Website Access ..... 11  
 The Key Map ..... 12  
 Adding & Removing Badges ..... 13  
 Programming Fingerprints ..... 14

**SYSTEM USAGE**

Pulling a Key ..... 17  
 Returning a Key ..... 19  
 Changing Apt/Unit# ..... 23  
 Editing Key Tags ..... 24

## New System Setup

Congratulations on the purchase of your new HandyTrac Compact Platinum Touch Key Control System! This guide includes complete setup and basic usage steps. Additional website and system features can be found in our online guides.

If you have any questions regarding this process, please contact a HandyTrac technician at 888-458-9994 or email [service@handytrac.com](mailto:service@handytrac.com). Full support guides are also available on our dedicated help site at [docs.handytrac.com](http://docs.handytrac.com).



Scan to see a video walk-through of a HandyTrac system installation

### Your system includes:

#### Platinum Touch Interface

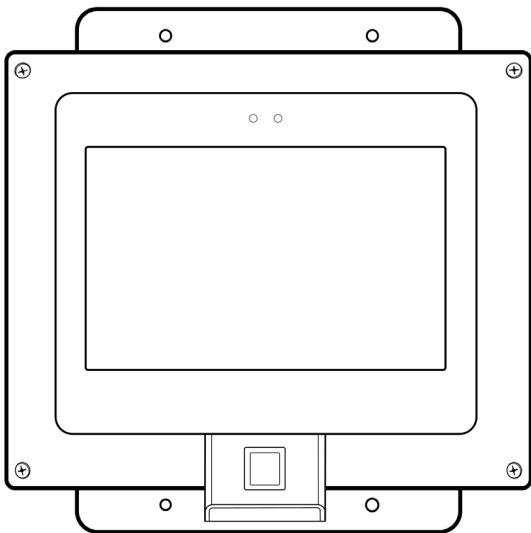

#### Panels with assigned Keytags

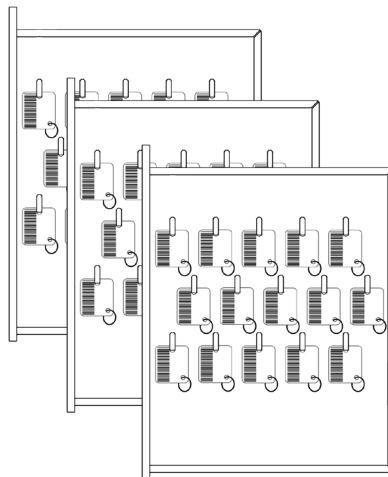

#### Cabinet

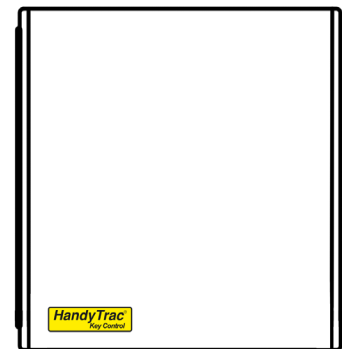

**Setup Pack Includes:** 1) Key Map 2) Installation and Operation Guide 3) Master Badge 4) Spare Keytags 5) Employee Badges 6) Cabinet Keys (taped to back of cabinet)

Building	Unit	Hook	Tag
17	170A	A1	0051
12	126A	A2	0074
14	149A	A3	0076
20	200A	A4	0095
15	155A	A5	0053
15	158A	A6	0062
10	106A	A7	0092
10	105A	A8	0016
19	345	A9	0001
17	176A	A10	0019
18	182A	A11	0031
11	110A	A12	0045
15	157A	A13	0089
18	184A	A14	0041
16	167A	A15	0037
15	154A	A16	0038

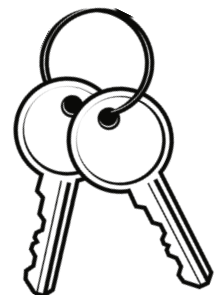
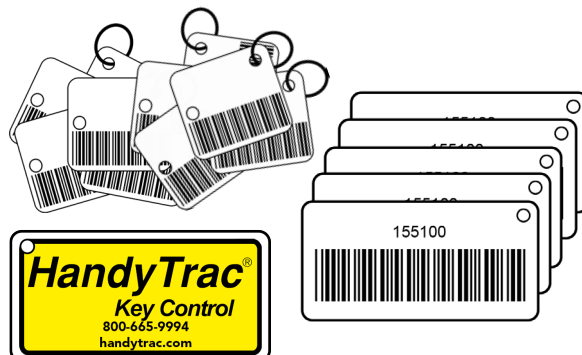
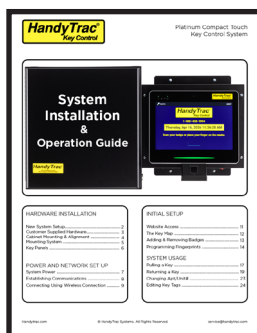

## Customer Supplied Hardware

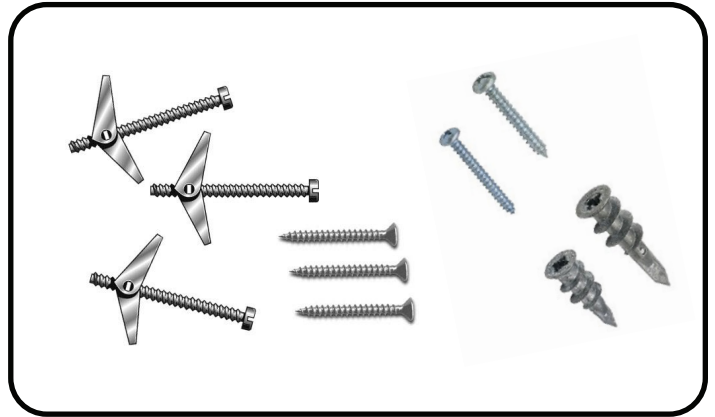

1. Uninterruptible Power Supply (UPS)
  - Minimum rating of 450VA. Required as part system warranty. Provides surge protection and backup battery power.
2. Mounting fasteners
  - Minimum 50 lbs load capacity for masonry, drywall, wood or metal studs.

## Tools Needed

1. Drill & Drill bits
2. Level
3. Phillips head screwdriver

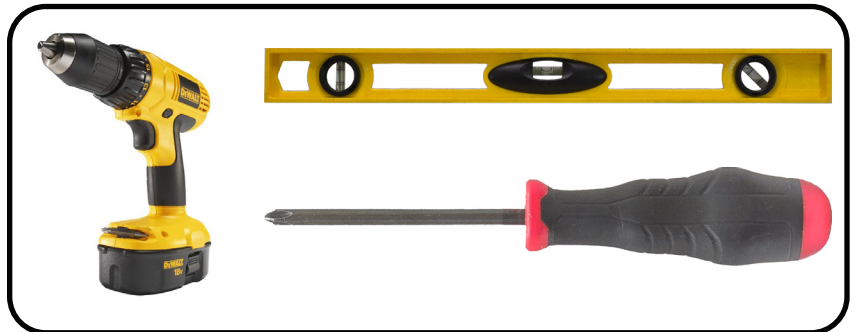

## Internet Connection

Available Options:

1. Certified Wi-Fi Dual Band 2.4G/5G  
802.11 a/b/g/n/ac  
**OR**
2. Standard 10/100/1000 Mbps Ethernet  
(CAT5e ethernet cable not included)



Familiarize yourself with these steps before you get started.  
The basic installation order is as follows:

1. Mount the cabinet to the wall.
2. Mount the HandyTrac Touch system keypad to the wall beside the cabinet.
3. Insert key panels in the cabinet(s).

**Do not place the manual backup keys inside the cabinet.**

## Mount the Cabinet

1. It is recommend to install the cabinet 50" off the ground. This will give a good average eye-level height for most staff members.
2. Align at least one (1) stud with one of the six (6) drilled mounting holes at the top of the cabinet.
3. Use a pencil to mark your holes. **A minimum of six (6) screws** are required for mounting the cabinet to ensure proper plumb, squareness, and stiffness.
4. When all holes are marked, use screws that penetrate at least two (2) inches into the stud or wall that are capable of holding at least 50 lbs. Follow the manufacturer's directions for all anchors.
5. Lift the cabinet into place and tighten all fasteners snug, but not fully. Place your level on top of the cabinet and check repeatedly as you tighten all of the fasteners.

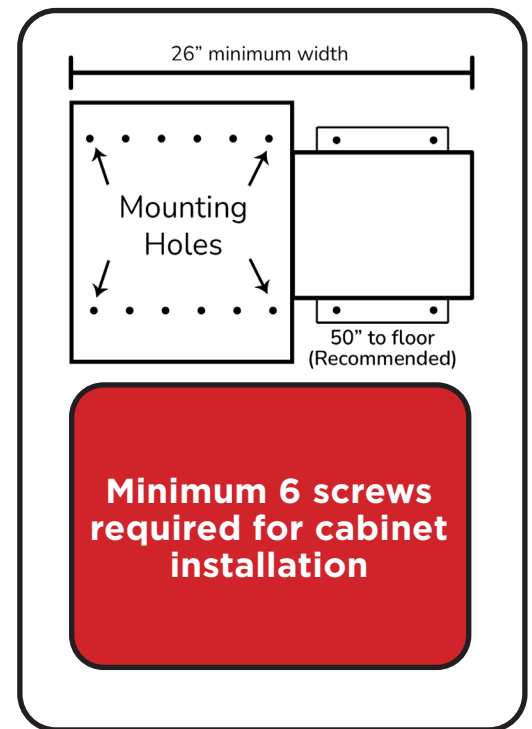

## Cabinet Alignment

Check the gap between door and door frame on all sides. If the gap is not uniform all the way around, the cabinet will have to be shimmed to compensate for the uneven wall surface.

- Use metal or plastic for shimming. Wood and rubber do not hold their shape well.
- If the door gap at top is greater than bottom, shim the top of the cabinet at right hand corner.
- If the door gap on the bottom is greater than the gap on the top, shim the bottom of the cabinet at the right hand corner.

## Mount the HandyTrac Touch

1. Before mounting the keypad, gently feed the electronic lock cables through the electronic lock cable port on the right side of the key cabinet. Make sure all three cables are in good condition.
2. Fasten the keypad to the wall with your mounting hardware. All four holes must be used to secure the Touch system to the wall. The Touch console should be mounted flush against the cabinet so that no wires are exposed.
3. Connect the electronic lock, light, and switch connectors inside the key cabinet. **The ends of each connector are labeled.**
4. Push extra cable lengths inside the main Touch control box. This prevents contact with the key panels during operation and protects the cables.
5. Apply the “**Scan Here**” sticker under the bottom right of the system. When placed under the system as depicted, the sticker will give employees a good spot to aim for when scanning badges and keytags.

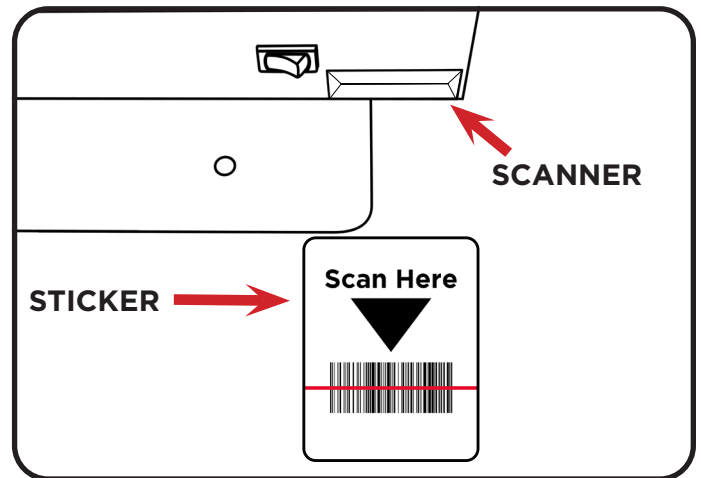
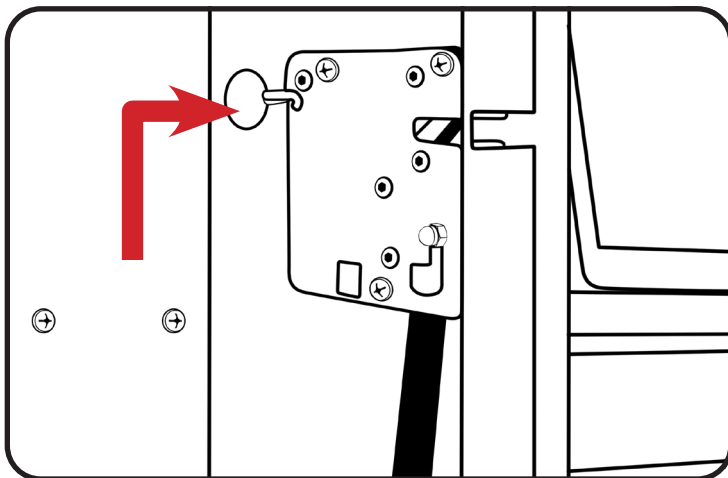
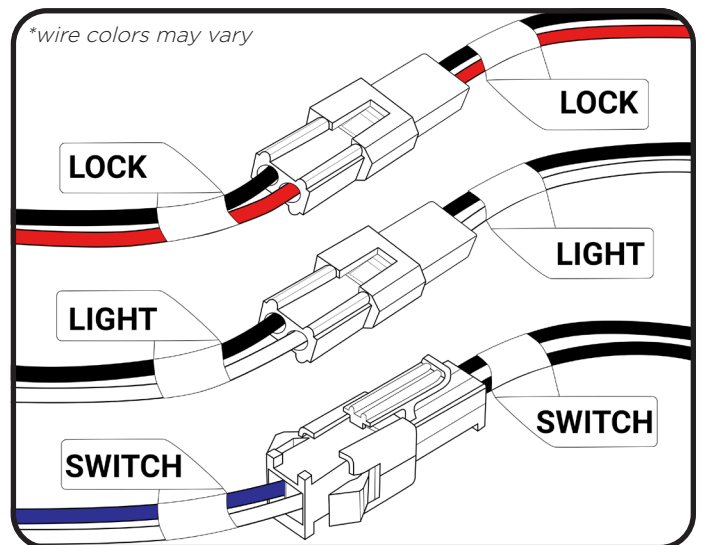
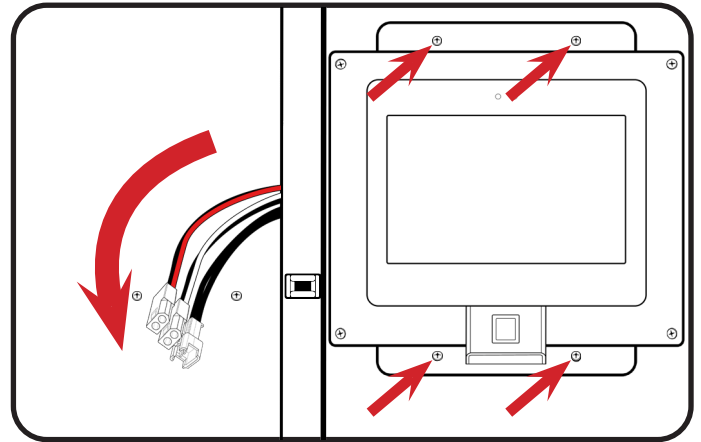

## Insert the Key Panels

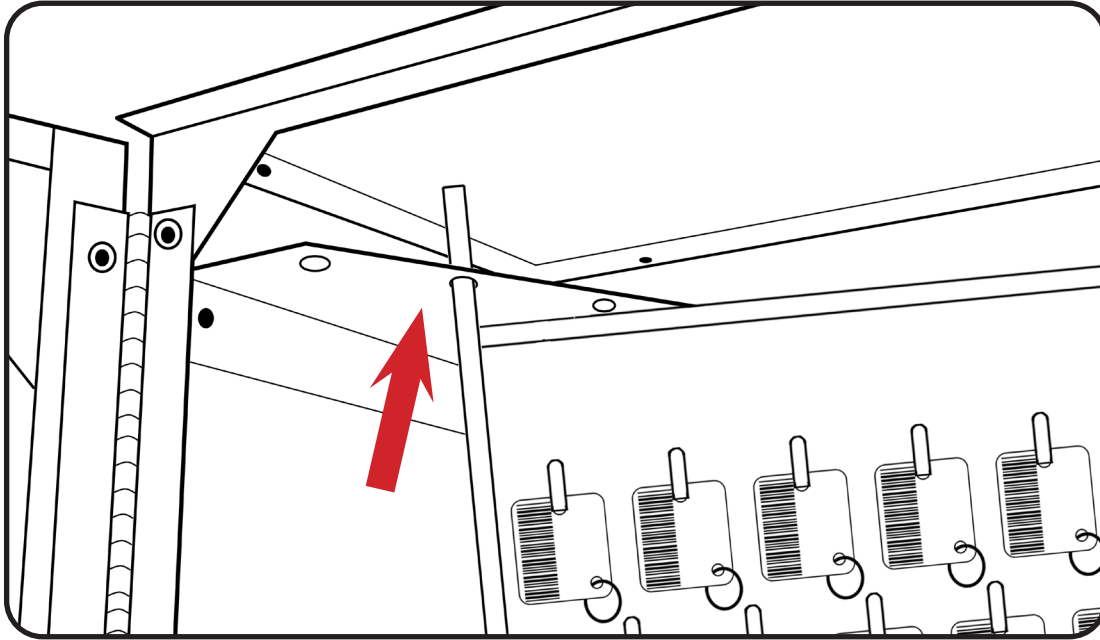

Insert the top panel mounting pin in to a hole on the top key panel mounting bracket. Pivot the bottom mounting pin into the corresponding hole in the bottom bracket and place the panel in. **Do not remove the key tags from the hooks.** Keys must be matched using the key map included with the setup packet. (Page 12)

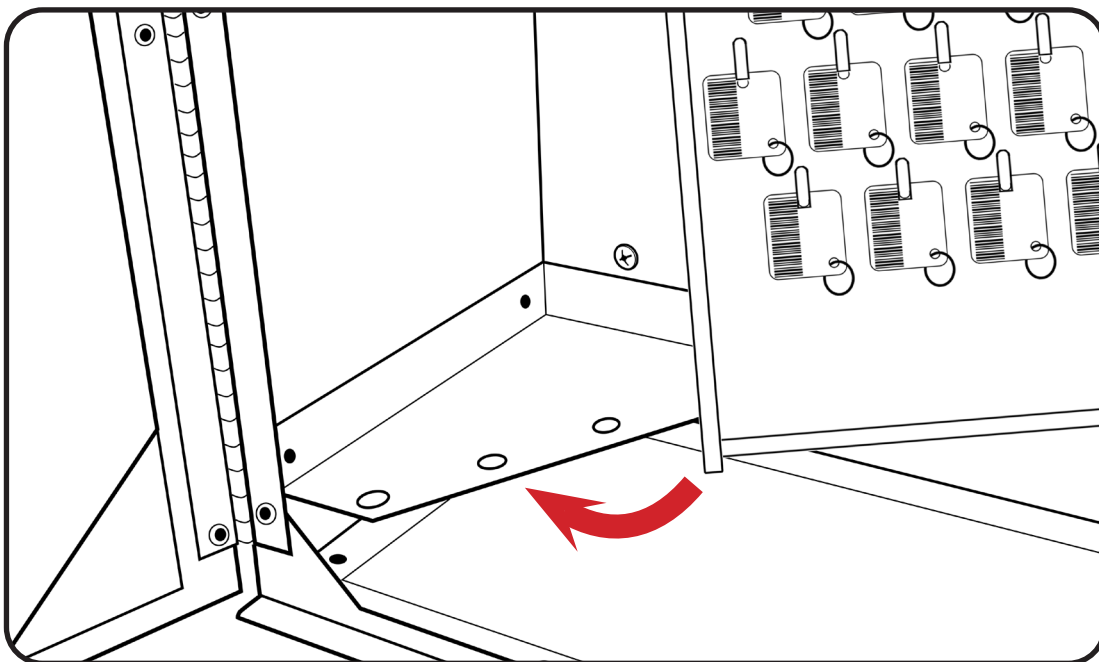

## System Power

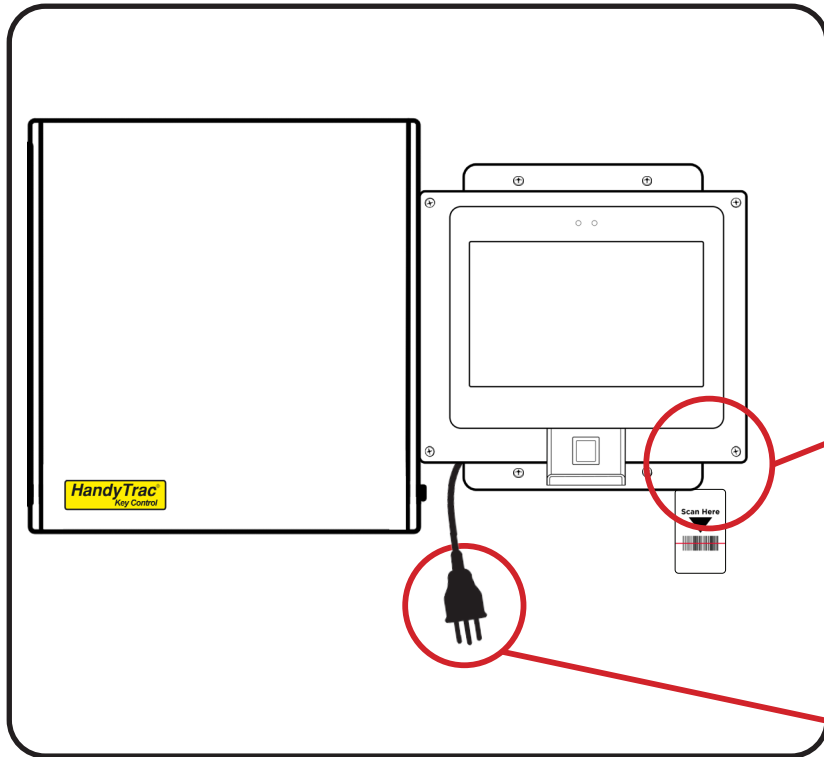

### Power Switch

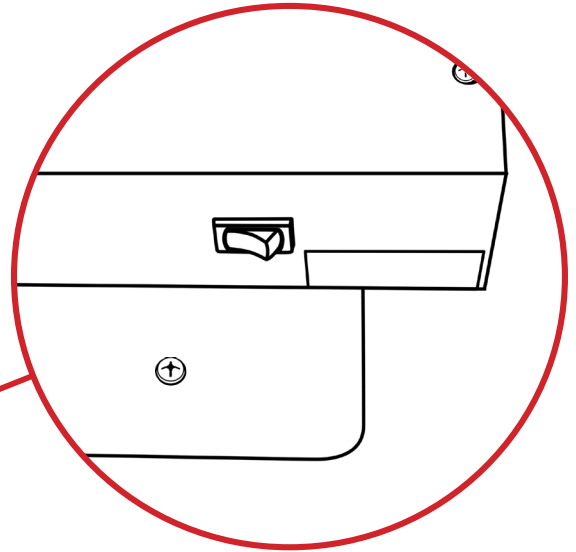

### UPS Battery Backup (Customer Supplied)

1. Plug the HandyTrac Touch power cable into a UPS Battery Backup. Be sure the HandyTrac Touch System is connected to an outlet that includes both **Battery Backup** and **Surge Protection**.
2. The **Power Switch** is located at the bottom right of the system, near the barcode scanner. Flip the switch to power the system on.
3. If your system does not power on, check to make sure the battery is connected in your UPS battery backup. Batteries are disconnected in new UPS systems for storage and transport. **Follow the manufacturer's installation and safety instructions for your UPS battery backup.**

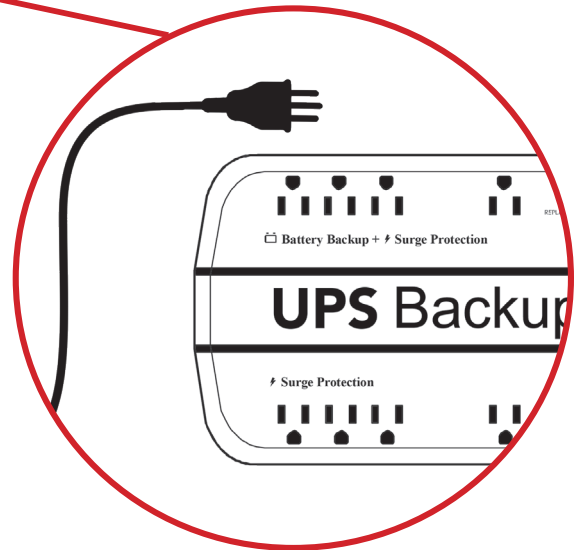

*Power over Ethernet (PoE) is not supported for HandyTrac Compact Platinum Touch systems.*

**NOTE: Your warranty will be voided if a UPS battery backup is not installed.**

## Establishing Communications

The HandyTrac Platinum Touch system supports both wired and WiFi network connections.

### Option 1: Wired Connection

1. An ethernet network cable can be connected to the ethernet network port located at the bottom-left of the system near the power cord. An ethernet cable does not need to be connected if you will be using a WiFi connection.
2. Once powered on, the system will display the main HandyTrac Touch system Time and Date screen. (*Pictured below*)
3. If the wired connection is not active, you will receive a “No Network” popup notification. You may need to contact your network administrator if devices require approval.
4. You can test your connection by **tapping the HandyTrac logo** on the display one time.
5. You should receive a notification that says **“Data Transfer was Successful.”**

### Ethernet Network Port

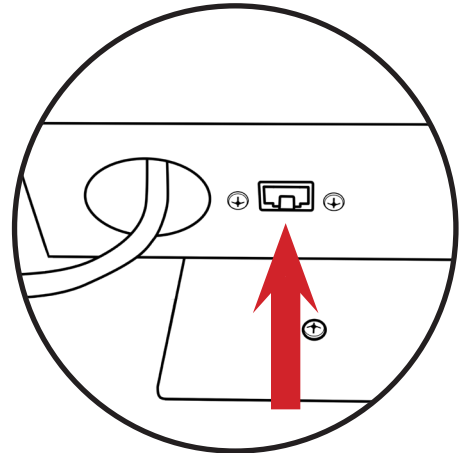

**Note: Tapping on “About” in the top right corner will list network connection information.**



### ABOUT

**Network Connection:** Ethernet  
**MAC Address:** 00:17:61:B6:3B:F8  
**IP Address:** 10.0.1.84  
**Netmask:** 255.255.255.0  
**Default Gateway:** 0.0.0.0  
**DNS Server 1:** 10.0.1.10  
**DNS Server 2:**

*\*Advanced network options are detailed on page 26*

## Option 2: Wireless Network

1. If you have the “No Network” popup on the display, tap on “OK” to dismiss it to display the Time and Date screen.
2. Once the system is at the main Time and Date screen, sign in by placing the Master Badge under the scanner at the bottom right of the system, then type in the PIN.
3. Make sure that the bar code is facing up and align it with the scanning laser that appears when motion is detected.



The Master Badge PIN is listed inside the small envelope containing the Master Badge.

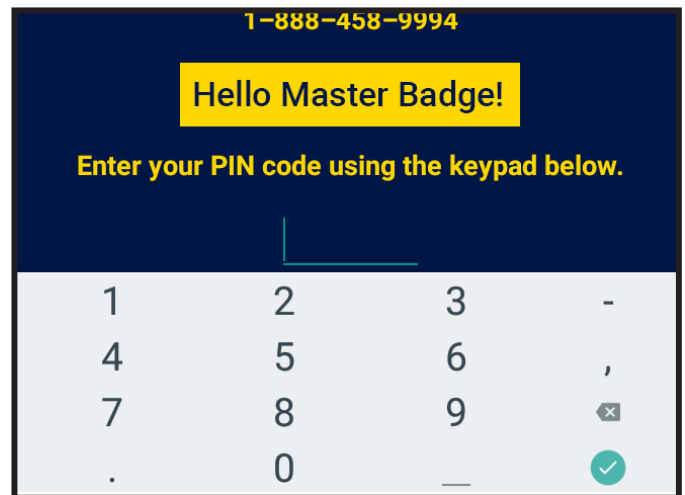
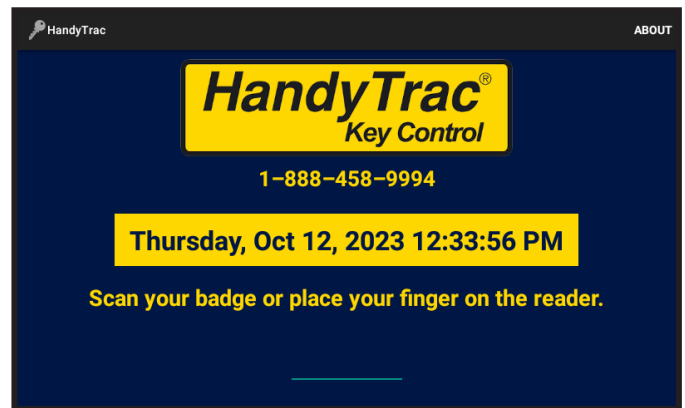
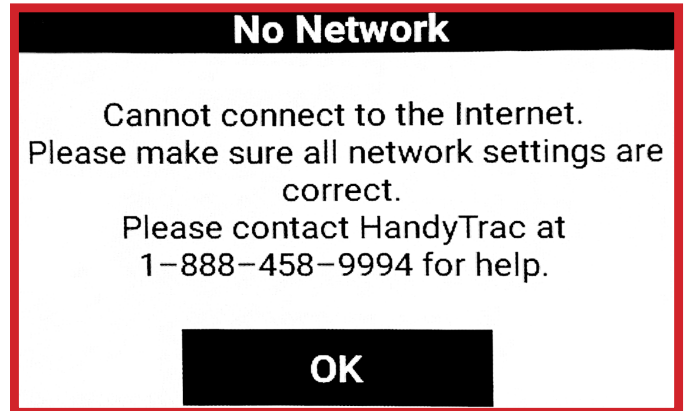

If you cannot locate the Master Badge, or if you have any issues logging in with the Master Badge, please call Technical Support for assistance at 1-888-458-9994.

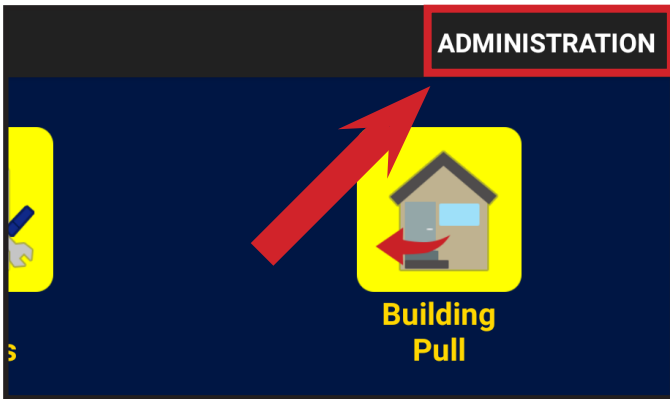

4. Tap “Administration” in the top right-hand corner of the touch screen.

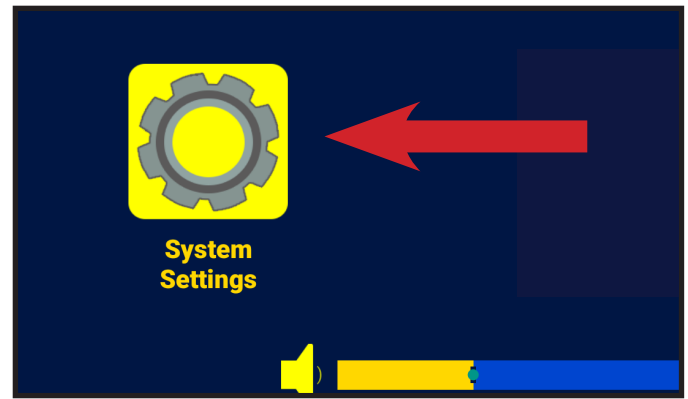

5. Tap the “System Settings” icon.

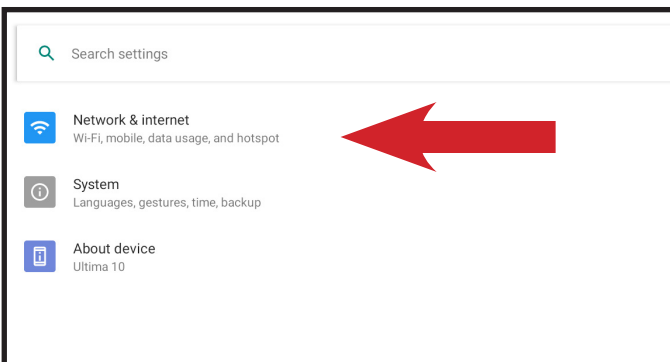

6. Select “Network & Internet” from the settings list.

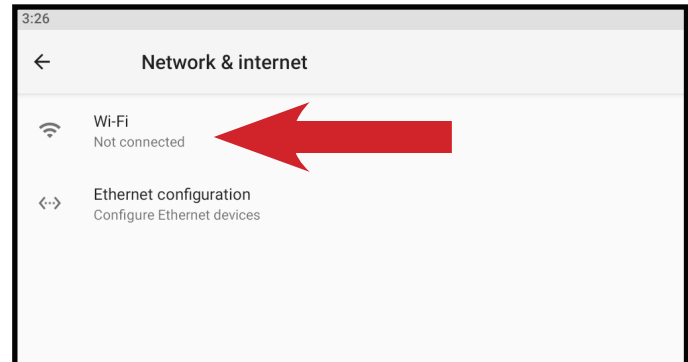

7. Select “Wi-Fi” from the network options.

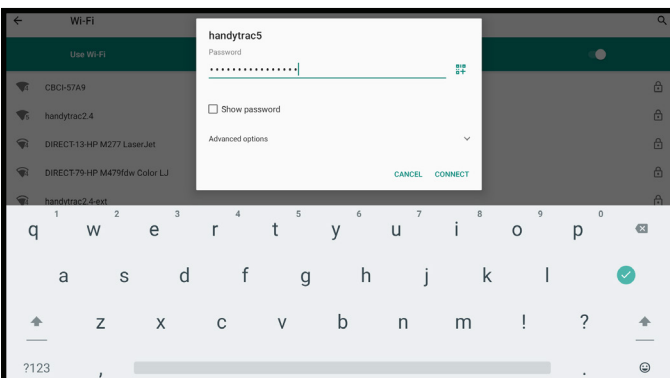

8. Make sure Wi-Fi is toggled “On,” then select your network from the list and enter your password when prompted. Passwords are case-sensitive.

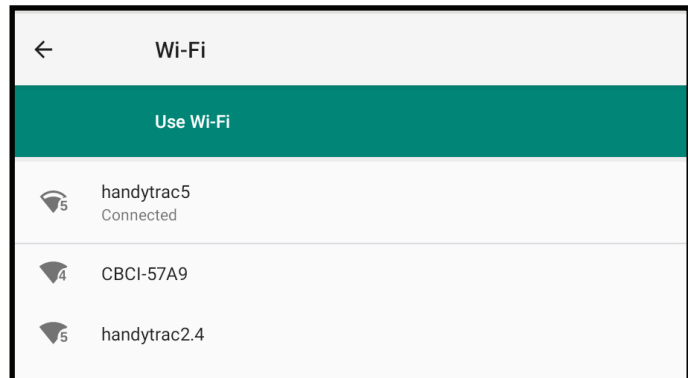

9. The status will change to “Connected” when **successful**. “Saved” or “Authentication Problem” are **errors**.

## Website Access and Setup Checklist

1. Visit **HandyTrac.com** and click Sign In at the top right corner to access your HandyTrac account.
2. The “**New Manager?**” link on the Sign In page allows you to email us the necessary information for your new account setup.
3. If required, Email us at **service@handytrac.com** or call **888-458-9994** and select Tech Support from the menu to speak with a HandyTrac Technician for account creation.

Detailed guides for all HandyTrac website features can be found at **docs.handytrac.com**



### Overview of Next Steps

1. Confirm the checklist
2. Match up keytags and keys according to the key map
3. Add employees on the website
4. Add fingerprints (if applicable)
5. Train staff on pulling and returning keys

### System Test Checklist

To test, log in to the HandyTrac keypad and request a key out using the Master Badge.  
(Page 18 - Pulling a Key)

- ✓ Barcode Scanner reads badges
- ✓ Correct units are listed
- ✓ Door opens automatically when a unit is requested
- ✓ The keytag you are directed to is the correct keytag
- ✓ Transaction data is updated on the website

# Matching Up Keys Using the Key Map

A printed key map is included with a new system in the setup packet.

The key map **must** be used to match keys to tags as **unit and tag locations are random**. The key panels will ship pre-populated with key tags on the indicated hooks.

Building	Unit	Hook	Tag	Building	Unit	Hook	Tag	Building	Unit	Hook	Tag
O	1501	A1	5088	A	101	C1	5055	D	405	E1	5003
I	903	A2	5054	H	803	C2	5016	C	305	E2	5030
G	704	A3	5051	J	1004	C3	5062	N	1401	E3	5021
P	1601	A4	5087	B	201	C4	5067	H	802	E4	5040
K	1101	A5	5081	B	205	C5	5053	D	403	E5	5095
	POOL	A6	5085	F	602	C6	5074	N	1404	E6	5048
G	705	A7	5076	I	902	C7	5075	C	301	E7	5037
K	1104	A8	5080	B	203	C8	5092	L	1205	E8	5042
M	1303	A9	5052	K	1105	C9	5089	E	501	E9	5015
M	1305	A10	5090	J	1002	C10	5082	Q	1705	E10	5019
N	1403	A11	5094	D	402	C11	5091	L	1203	E11	5043
J	1003	A12	5097	M	1302	C12	5060	K	1103	E12	5044
F	605	A13	5098	M	1304	C13	5072		CLUBHOUSE	E13	5049
L	1201	A14	5073	K	1102	C14	5064	J	1005	E14	5018
A	103	A15	5096	O	1505	C15	5058	P	1605	E15	5022
Q	1702	B1	5059	F	603	D1	5066	I	901	F1	5012
L	1202	B2	5086	A	104	D2	5065	C	303	F2	5046
B	202	B3	5056	H	804	D3	5070	L	1204	F3	5006
G	701	B4	5063	E	502	D4	5083	D	404	F4	5039
M	1301	B5	5093	I	904	D5	5078	E	505	F5	5002
A	105	B6	5069	G	703	D6	5029	H	801	F6	5041
	STORAGE	B7	5071	P	1604	D7	5010	G	702	F7	5026
E	503	B8	5050	J	1001	D8	5023	Q	1703	F8	5032
N	1405	B9	5061	O	1504	D9	5031	A	102	F9	5024
B	204	B10	5099	Q	1701	D10	5004	C	304	F10	5005
P	1602	B11	5079	O	1502	D11	5036	N	1402	F11	5045

Once keys are matched to tags, **shred** the printed key map. The key map will no longer accurately reflect your key locations once the system is in use. The key map changes continuously as you use the system, with the most up to date version is available on the website to authorized users. After initial setup, the key map should only be used in emergency situations, such as complete power loss.

*The key map depicted on this page is provided only as an example. Your key map will differ.*

## Adding an Employee Badge

1. On the website, select “Employees” from the menu.
2. Click on the blue Add Employee button.
3. Fill out the fields including name, the six-digit badge number, and create a four-digit PIN.
4. Choose an access level for the employee. Most staff will only need Employee Access to pull keys, but managers and administrators should have Master Access. Master Access allows editing units, tags, and fingerprints.
5. Choose a language that is displayed to the employee when they sign in to the HandyTrac keypad. When done, save the new employee.
6. Once all your employees are added on the website, go to the HandyTrac system keypad and **tap on the yellow HandyTrac Logo one time**. This will force a communication and update the system with all current employees.

**Employee Badge | Add**

Active \*  
Yes

First Name \*  
First Name

Last Name \*  
Last Name

Badge Number \*  
Badge Number

PIN \*  
1111

Access Level \*  
Employee

Language \*  
English

Cancel Save

4.12

**Note: It is critical that all employees using the HandyTrac system have their own badge and PIN. If badges and PINs are shared, the audit trail will not be valid.**

## Editing or Removing an Employee Badge

1. To edit an employee badge, click “Edit” at the end of the line for the employee from the Active Employees list.
2. You can edit the Active status, badge number, PIN, access level, or language. You cannot change the name associated with a badge.
3. To remove an employee badge from the system, simply change the “Active” field to “No” and save. This will remove that employee’s access and free up the badge to be re-added with a new employee.

## Adding Fingerprints for Employees

(Master Access is required. Firmware v4.11+ is depicted in this guide.)

Employees must be added on the website first. Once they are added to your Active Employees list, you can add their fingerprint to their profile.



1. Before logging in to the HandyTrac system, tap on the HandyTrac Logo on the screen **one time**. This will force a communication and update the system with all current employee information.
2. You should receive a notification that says "Data Transfer was Successful." Once synced, sign in with Master Access.

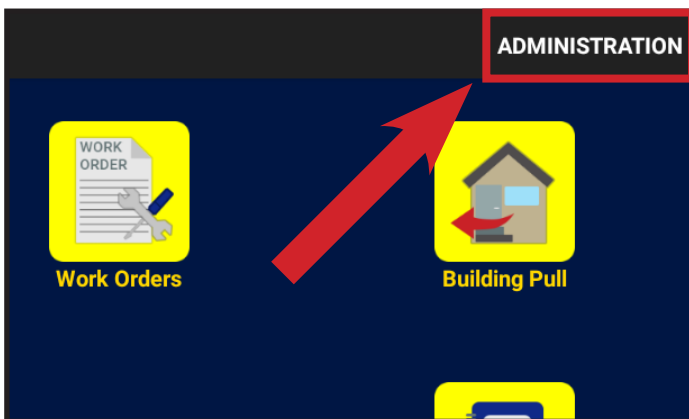

3. Tap on the word "Administration" in the top right corner of the screen.

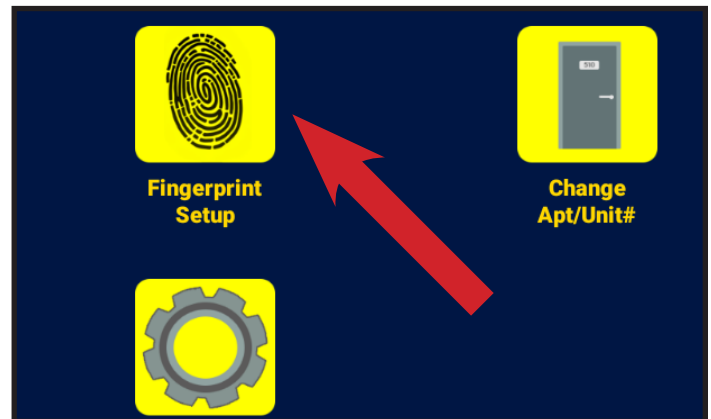

4. Tap "Fingerprint Setup" from the Administration menu.

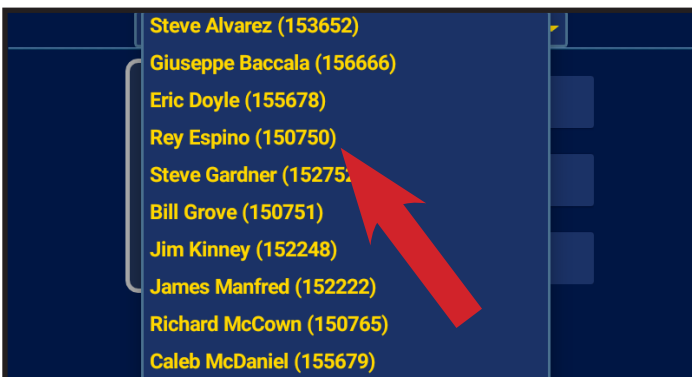

5. Select the employee whose fingerprint you want to set up from the list.



6. Once the appropriate employee is selected, tap on Register fingerprint.

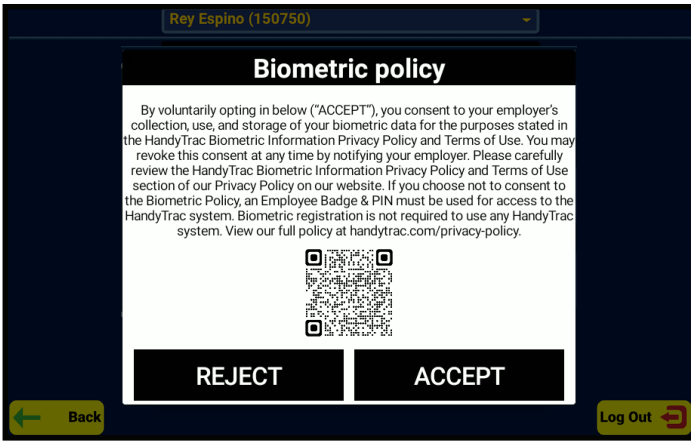

7. Read and Accept the biometric data usage terms and conditions.

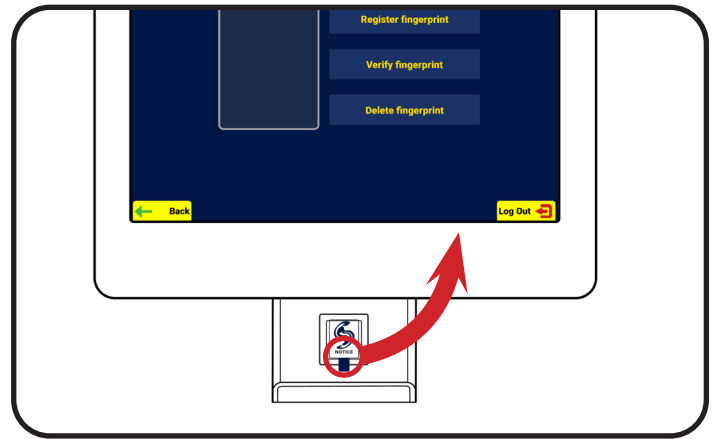

8. Make sure the protective film is removed from the fingerprint reader.

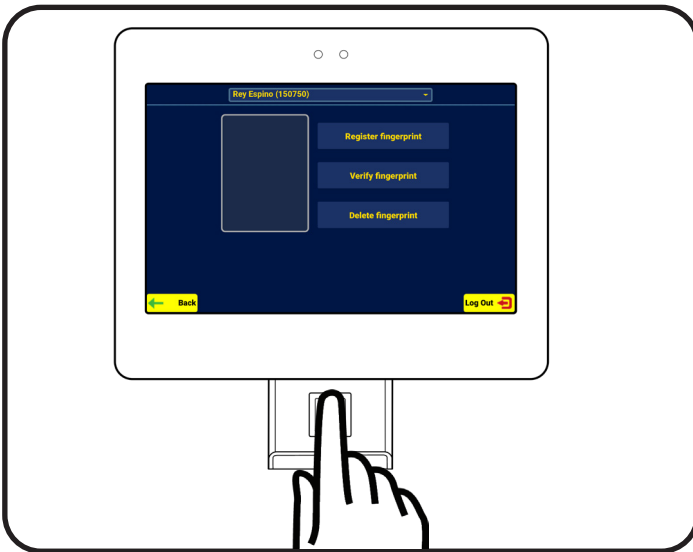

9. Place your finger on the reader.

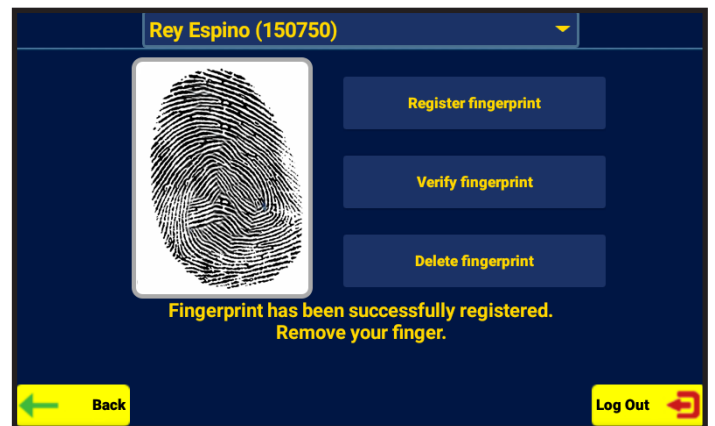

10. The system will chime and notify you of a successful read. **Repeat** until the system indicates the print is successfully registered. Place your finger on the reader the same way each time.

**Notes:**

- It is recommend you test your fingerprint access by logging out of the HandyTrac system and signing back in by placing your finger on the reader.
- Badges and PINs can still be used in the event a finger is cut or no longer reads properly.
- Fingerprints are removed when an employee is deactivated on the website.
- The fingerprint preview should display a well defined and even print.
- If you have shallow fingerprints, use a larger finger on a non-dominant hand.
- Biometric fingerprint log-in requires consent to the HandyTrac Biometric Information Privacy Policy and terms of use as found in our full privacy policy at [handytrac.com/privacy-policy](http://handytrac.com/privacy-policy).

## Accessing the Platinum Touch System

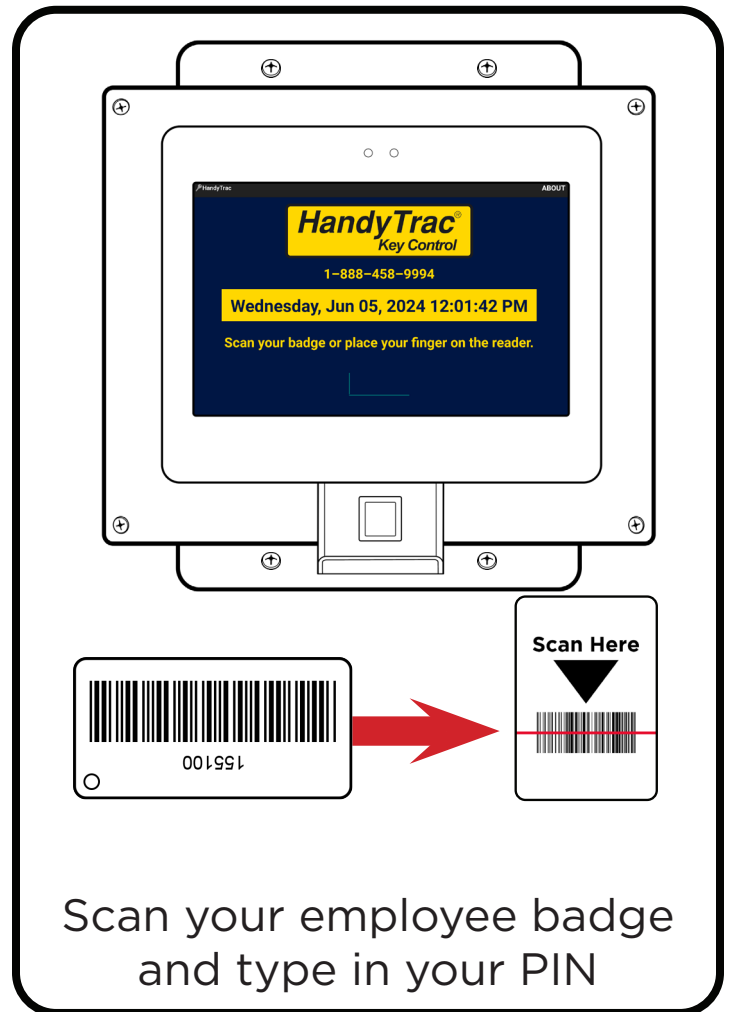
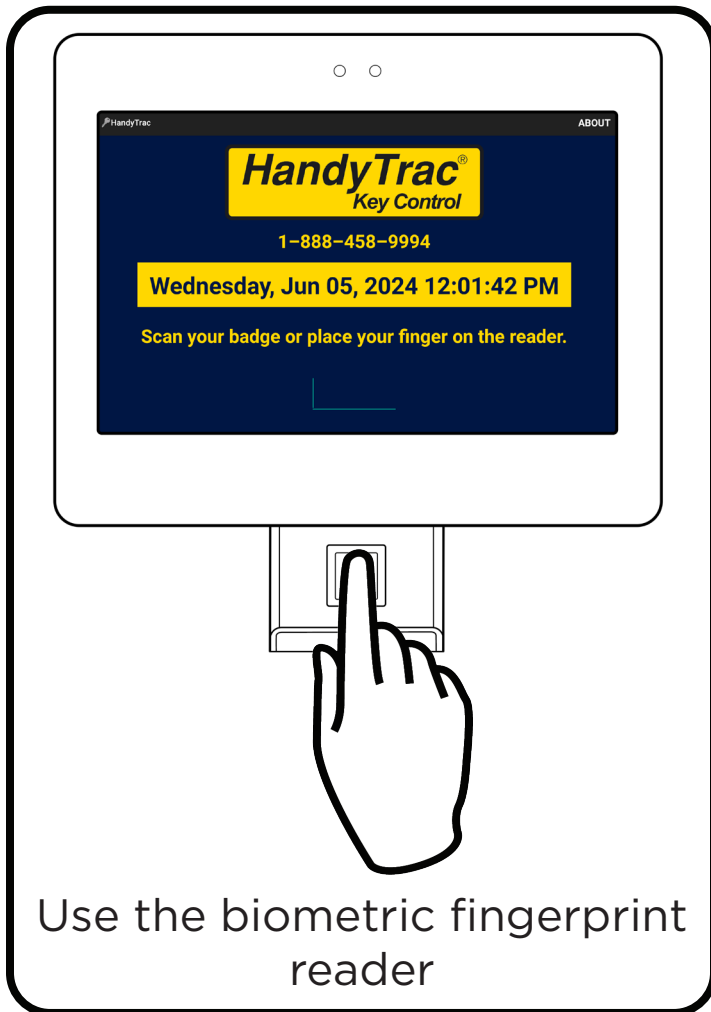

Use the biometric fingerprint reader **OR** scan your badge and enter your PIN.

The HandyTrac Platinum Touch system must be at the default **Time and Date** screen for an employee to gain access.

Any actions taken on the system, such as pulling or retuning a key, require an employee to be signed in to the system.

## Pulling a Key

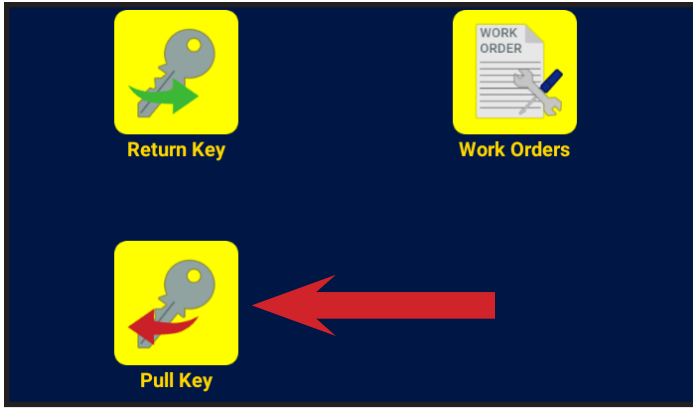

1. Tap the “Pull Key” icon



2. Tap an Activity Code. Choosing an appropriate Activity makes your audit trail more accurate.



3. **Tap the unit** from the list. You can use the Search box to find units, or, if you have buildings programmed, you can filter with the “All buildings” drop-down.

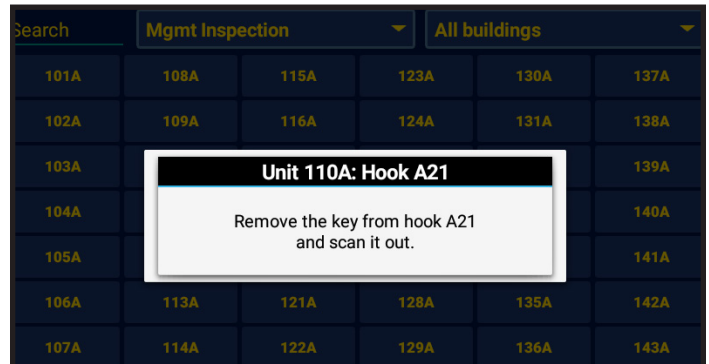

4. The system will electronically pop open the door and tell you where to find the unit key you requested. **Scan the key out** to verify it is the correct tag.



5. If you need multiple keys, continue to select units from the list.



6. Once you are finished pulling keys, **close** the cabinet door and tap **Log Out**.

## Notes on Pulling Keys



If the Apartment/Unit# you are looking for is “grayed-out”, it has already been requested out, or it is restricted. Tapping the unit will provide additional information.



If you are requesting multiple keys for different purposes, you can change the activity code by tapping the current activity code at the top.

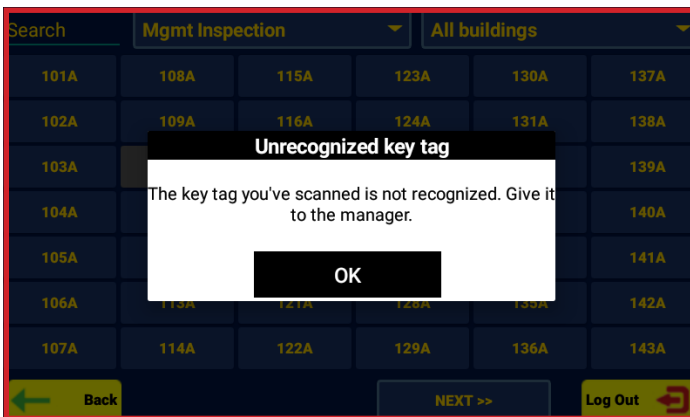

If you scan a keytag that is not assigned to a unit, it will be rejected. **Do not** place the keytag back in the cabinet as it does not belong in the system.

The “Search Key Tag Report” on the website can help with unknown key tag identification.

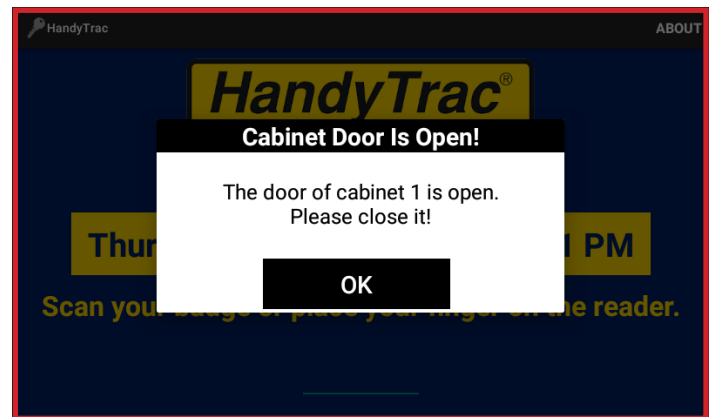

**Close** the door before logging out of the system. The cabinet door will only open **one** time per session. You will be automatically timed out after 60 seconds with no action.

These security measures prevent employees from taking action under the login of a different employee.

## Returning a Key

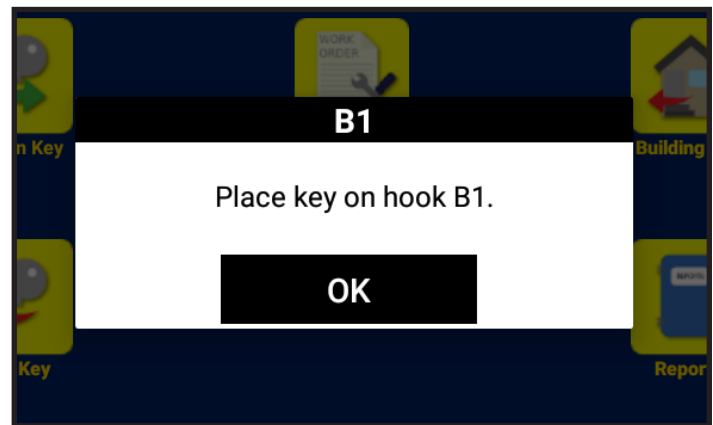
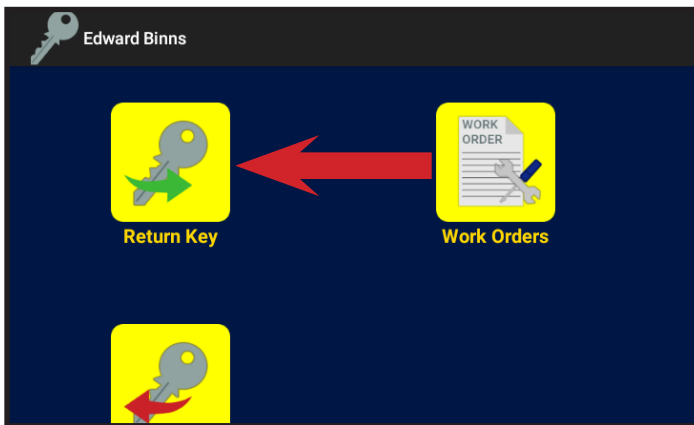

1. Log in to the HandyTrac system.
2. Tap on Return Key.
3. **Scan** the keytag.
4. Place the keytag on the assigned hook.  
Scan all keys in one after the other.
5. **Close** the cabinet door(s).
6. **Log Out** of the system.

---

## Key Rotation

When a key is returned to the system, it will be assigned to a **random** empty hook. Because of key rotation, printed key maps become inaccurate and should not be referenced once the system is used. This is a security measure to prevent memorization of key locations.

The Key Map on the website is always updated with the new key locations and it is available at any time to authorized users once signed in.

## Occupied Hooks

When a key is scanned in to the system it will be assigned to a random empty hook. If there is already a key on the hook, then **that key is on the wrong hook.**

Do the following to correct this error:

1. Remove the key that is on the hook.
2. Place the originally scanned key on the hook.
3. Scan in the incorrectly placed key as if it were a normal key return.
4. Place on assigned hook.
5. Repeat until all keys are returned to empty hooks if necessary.

## Work Order Key Pull

Work order numbers can be entered directly instead of selecting an Activity.

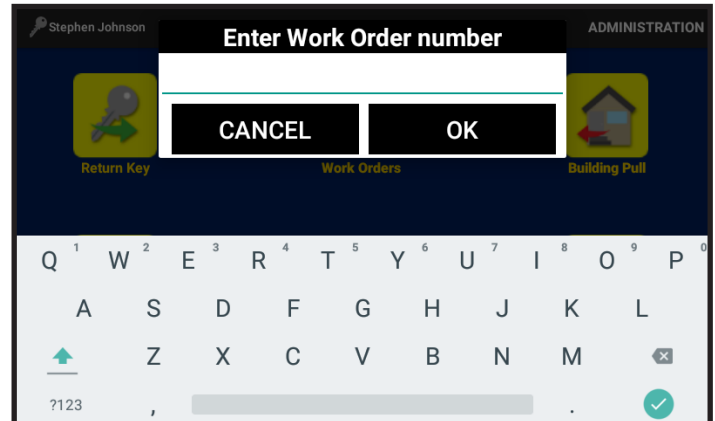
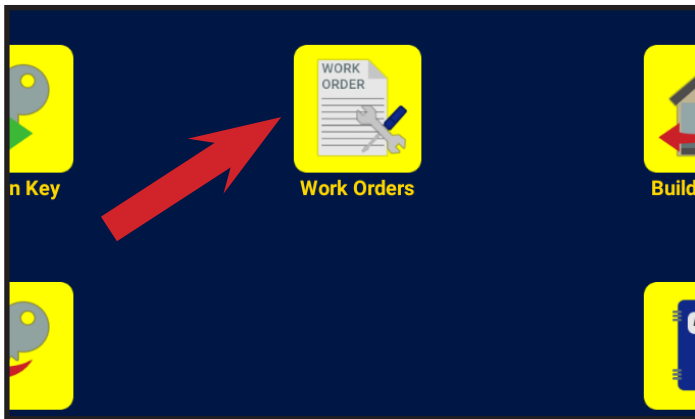

1. Log in to the HandyTrac system.
2. Tap the "Work Order" icon.

3. Type the work order number and tap OK.
4. Continue the key pull process as detailed previously. (Page 17)

Work orders can be entered via 3rd party software integration. Contact HandyTrac Service to see if the Touch Platinum system is compatible with your work order software.

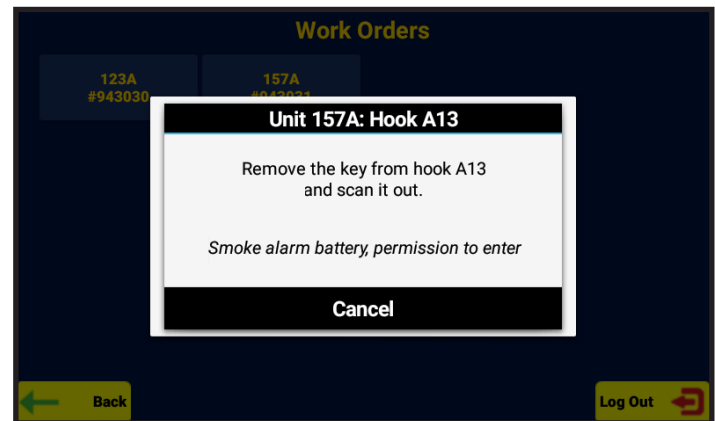
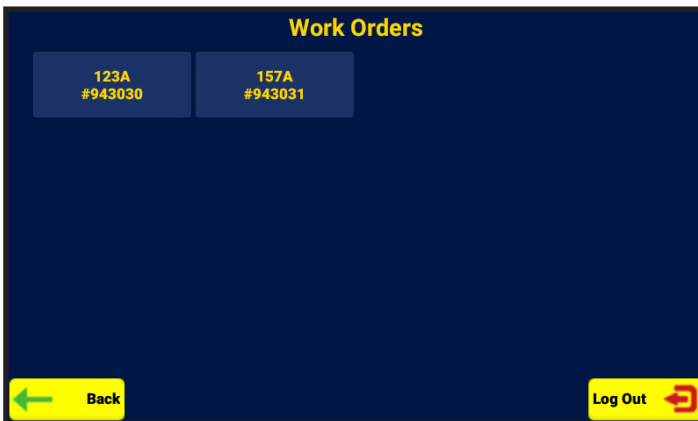

1. If work orders have been assigned to an employee, the work orders will be listed when an employee selects the Work Order icon.

2. Selecting the work order will provide details of the work order and automatically request the unit key.
3. Complete the key pull process as detailed previously. (Page 17)

## Using Building Pull

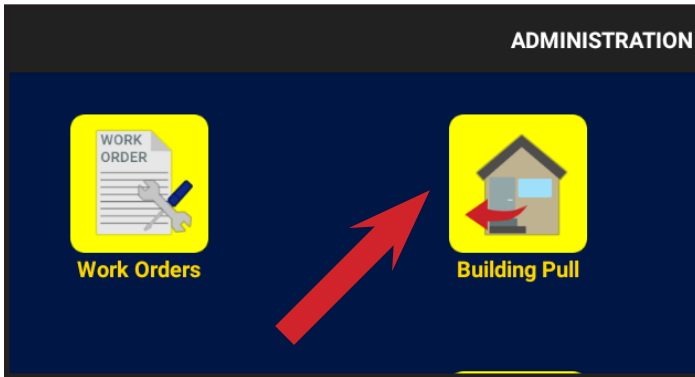

1. Log in to the HandyTrac system and select the Building Pull icon.

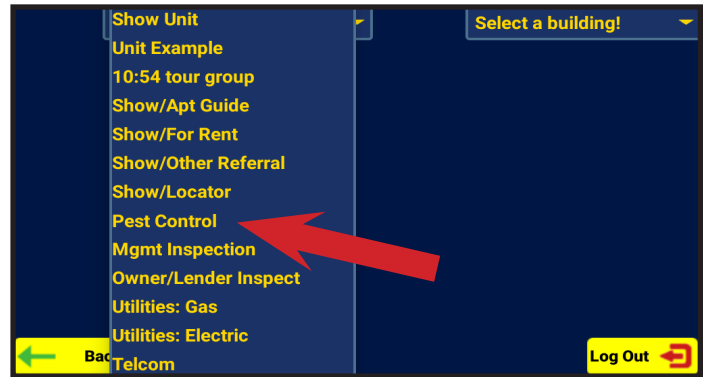

2. Select the Activity that will be performed for the Building Pull.

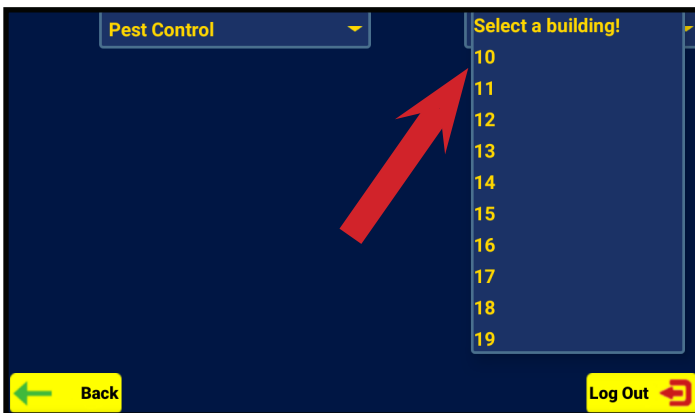

3. Select a building from the list. The cabinet door will open and direct you to the first available key in the building.

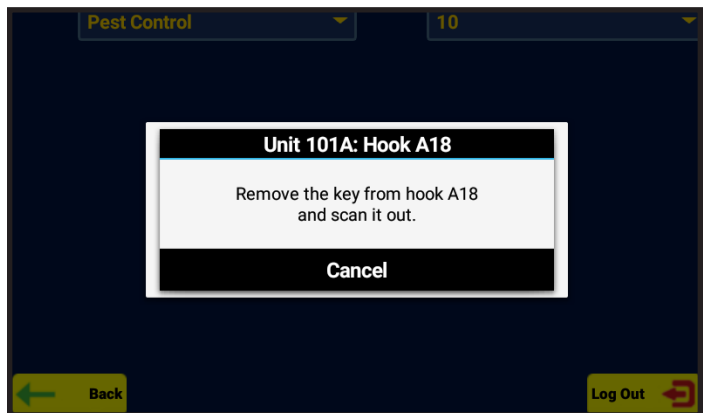

4. Remove the key for the unit and **scan the key out**. Once a key is scanned, the system will automatically provide the next key in the building. Continue pulling and scanning each unit until the building pull is complete.

### Notes:

- If a key is not in the cabinet, tap "Cancel" to skip the unit and continue the Building Pull.
- If a key is already out or if it is restricted, the unit will be skipped.
- Buildings must be programmed in the system to use Building Pull.

## Administration Menu

*(Master Access is required)*

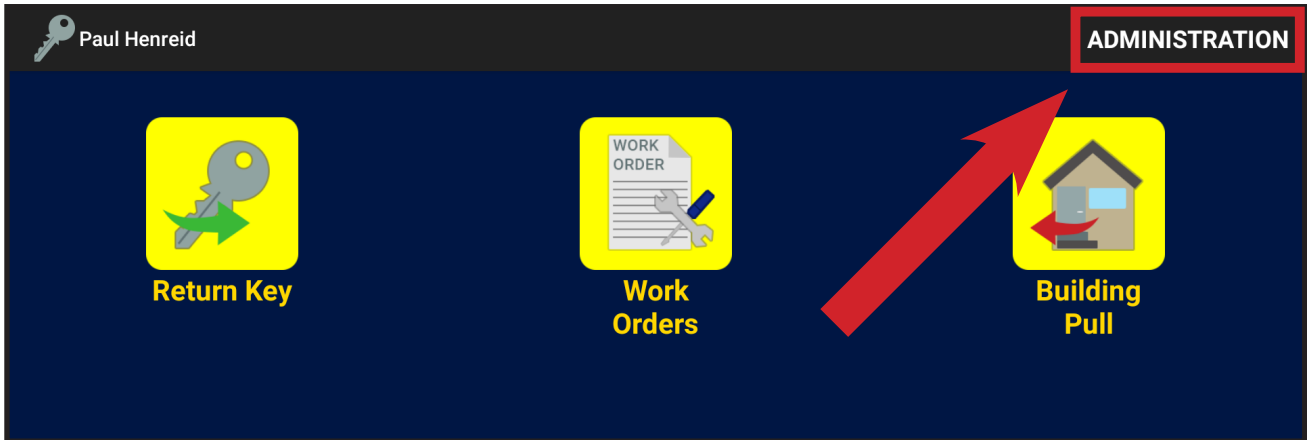

Sign in to the system using a badge with Master Access, then tap "Administration."

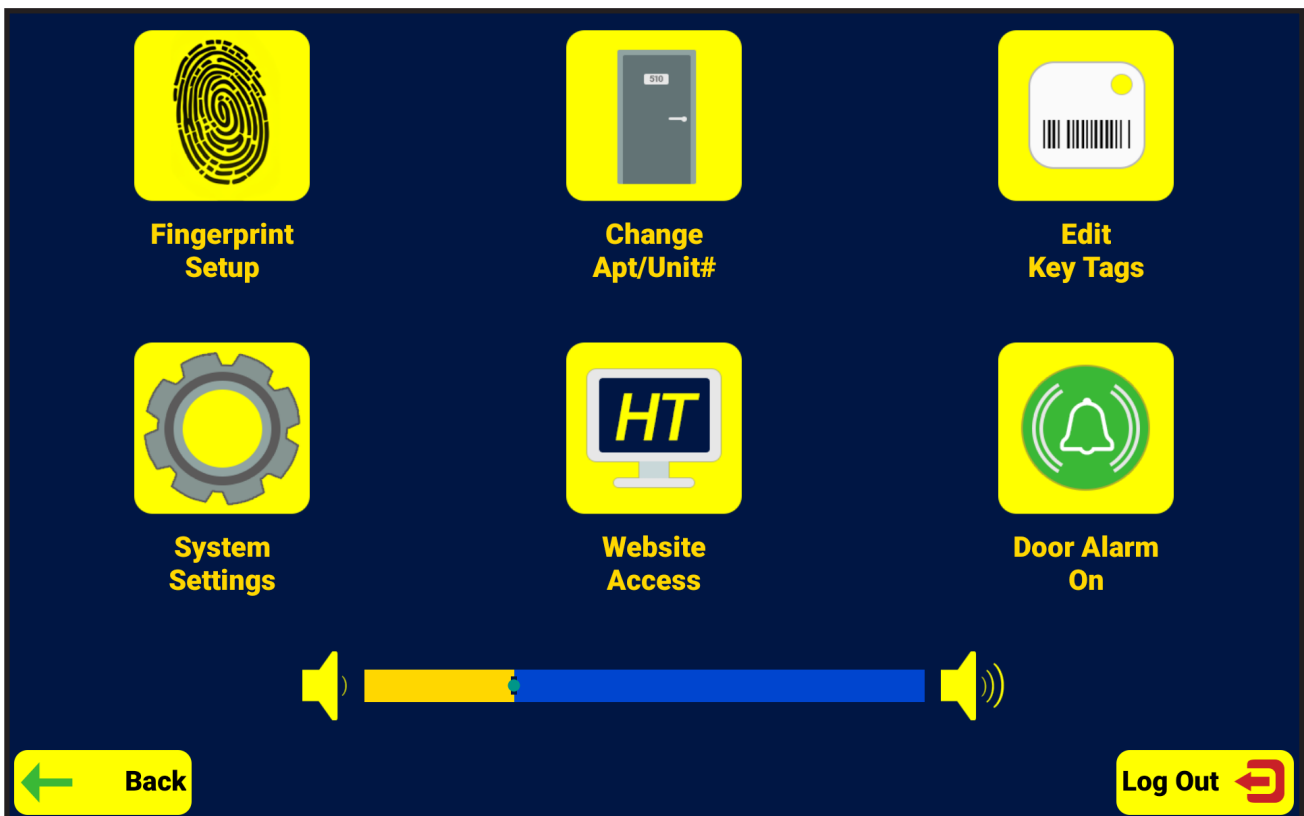

The Administration Menu includes a number of system functions and advanced settings. Specific administrative processes are detailed on the following pages.

## Changing Apt/Unit#

(Master access is required)

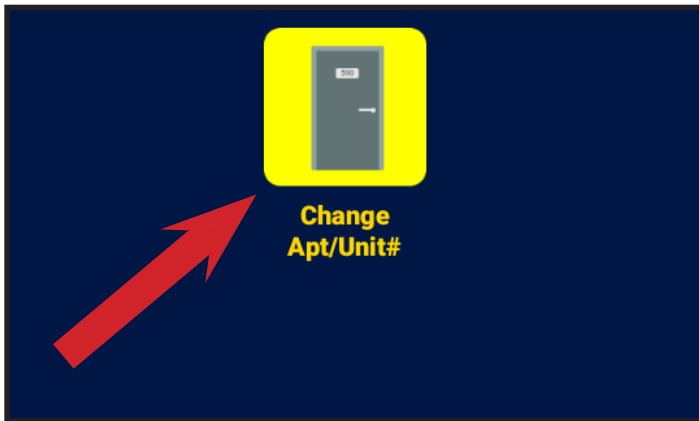

1. Under the Administration Menu, tap on Change Apt/Unit#.

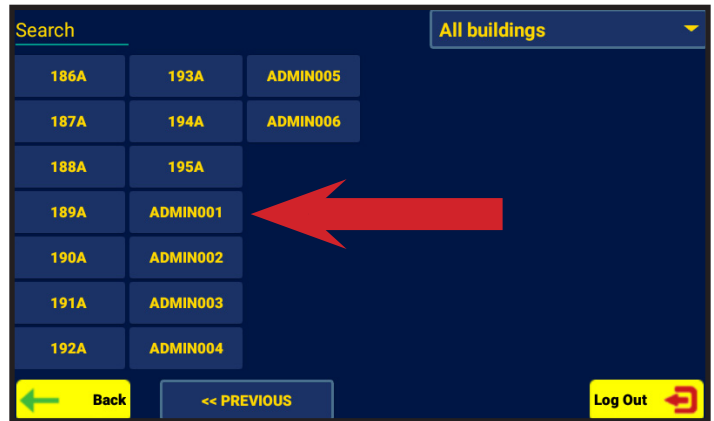

2. You will see the full list of units and any extra locations, if available.

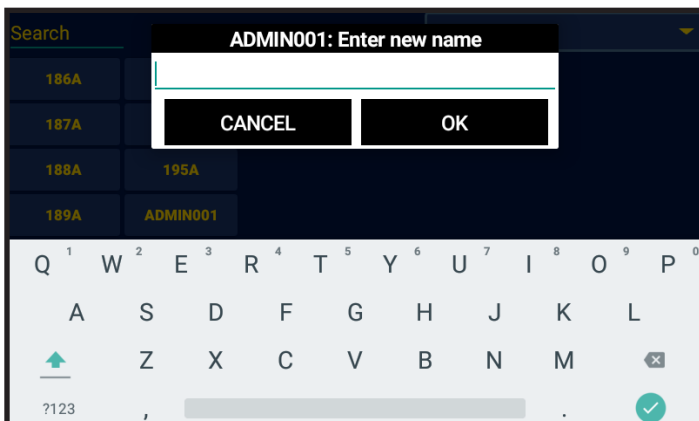

3. Tap on the unit and type in a new name using the on-screen keyboard.

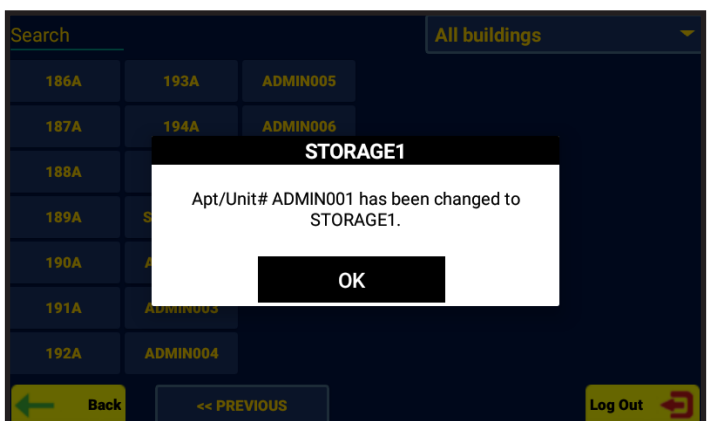

4. The system will confirm the new name has been entered.

## Adding A New Unit

New units are added by replacing extra locations in the system. In general, extra locations are named ADMIN or XTRA. To add a new unit, you must do the following in this order:

1. Rename an extra location.
2. Replace the keytag as detailed on the following page, if required.

## Editing Key Tags

(Master access is required)



1. Under the Administration Menu, tap on “Edit Key Tags.”

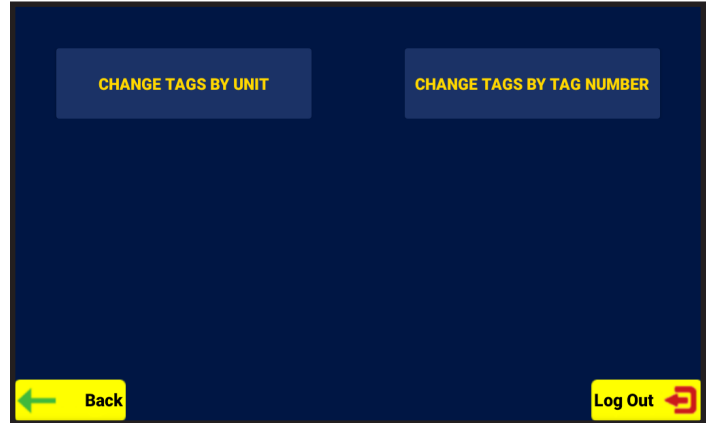

2. You have the option to change a tag based on the Unit **OR** Tag Number.

### Change Tags By Unit

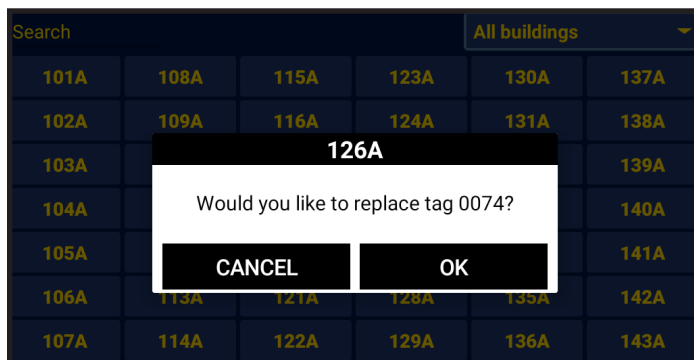

3. To edit based on **UNIT**, select the unit from your list and confirm you wish to replace the existing key tag.

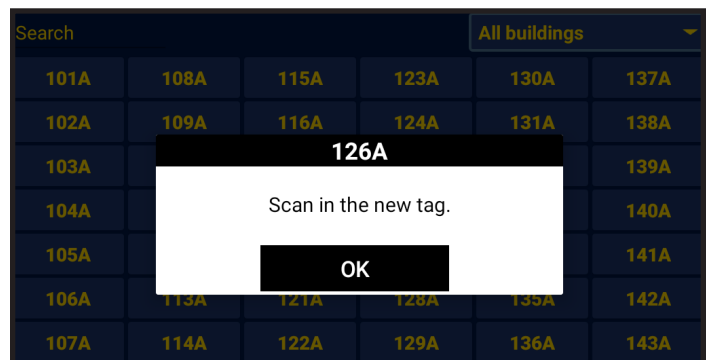

4. Scan your new tag. The system will open the door and assign the tag to a hook.

### Change Tags By Tag Number

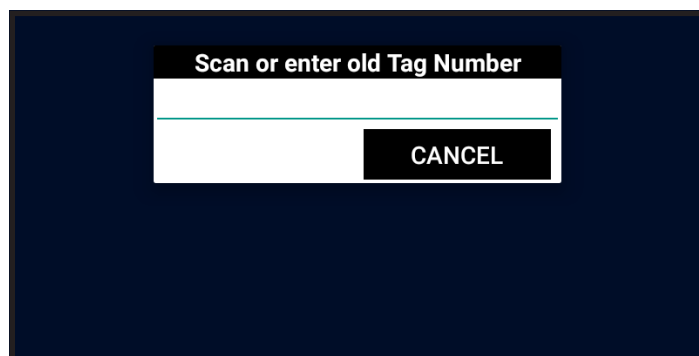

3. To edit based on **TAG NUMBER**, scan or type the old tag number.

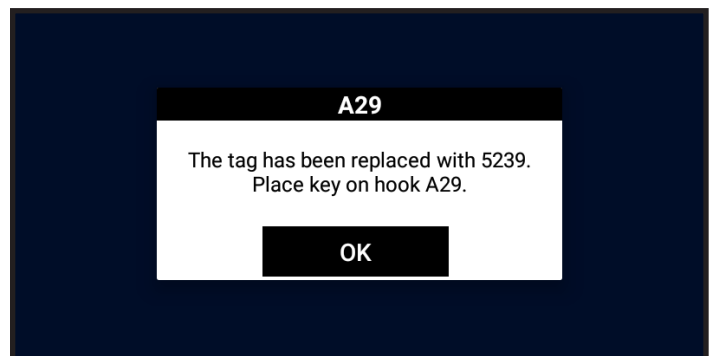

4. Scan your new tag. The system will open the door and assign the tag to a hook.

## On System Reports

### Keys out report 06/09/22 04:27 PM

**THESE KEYS ARE OUT:**

Employee	Building	Unit	Activity	Date	Time
Stephen Johnson		AAR11	Show/Other Referral	06/09/22	04:16 PM
Sub Total: 1					

**THESE KEYS HAVE BEEN REQUESTED, BUT NOT SCANNED:**

Employee	Building	Unit	Activity	Date	Time
Stephen Johnson	1	26	Show/Other Referral	06/09/22	04:16 PM
Sub Total: 1					

END OF REPORT

**Back**
**Log Out**

1. The **Keys Out Report** is available to all employees when they log in to the HandyTrac Touch system.

### Transactions 06/28/22 03:54 PM

**DATE RANGE:** 06/28/22 - 06/28/22

Employee	Unit	Key Hook	Key Tag	Activity	Exception	Date	Time
Stephen Johnson				EXCEPTION	Timed Out	06/28/22	10:55 AM
Stephen Johnson	AAR11	A40	9413	Return Key		06/28/22	11:45 AM
Stephen Johnson	AAR11	A40	9413	Return Key		06/28/22	11:46 AM
Stephen Johnson				EXCEPTION	Timed Out	06/28/22	11:47 AM
Stephen Johnson				Building Pull		06/28/22	01:37 PM
Stephen Johnson				EXCEPTION	Timed Out	06/28/22	01:38 PM
Stephen Johnson				Building Pull		06/28/22	01:39 PM
Stephen Johnson	1 (2)	A37		Show/For Rent	No Scan	06/28/22	01:39 PM
Stephen Johnson				EXCEPTION	Timed Out	06/28/22	03:50 PM
Stephen Johnson	AAR11	A40	6676	Return Key		06/28/22	03:52 PM
Stephen Johnson			0858	Return Key	Tag Not In System	06/28/22	03:52 PM

**Back**
**From:** 06/12/24 **To:** 06/12/24 **Search report**
**Log Out**

2. The **Transactions Report** is available to those with Master Access.

## Wireless Network: Advanced Options

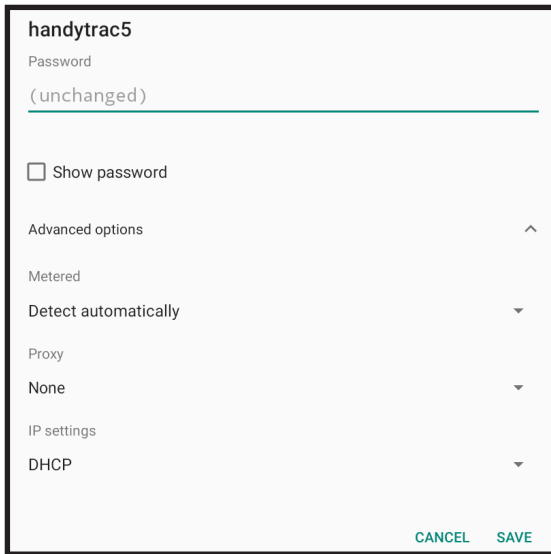

1. Tap the network name, then select the “pencil” icon at the top right to access Advanced Options.
  2. You can configure advanced network options such as Proxy and Static IP settings.
- HandyTrac recommends DHCP IP address reservation on the network rather than manually setting static IP information.
  - Do not modify advanced options unless directed to by your helpdesk or internal IT.
  - Some secure networks require specific device approval. Contact your internal IT or Network Administrator if required.

**NOTE:**

*The HandyTrac system does not support on-system VPN login or additional guest network terms and conditions acceptance.*

## Wired Ethernet Network: Advanced Options

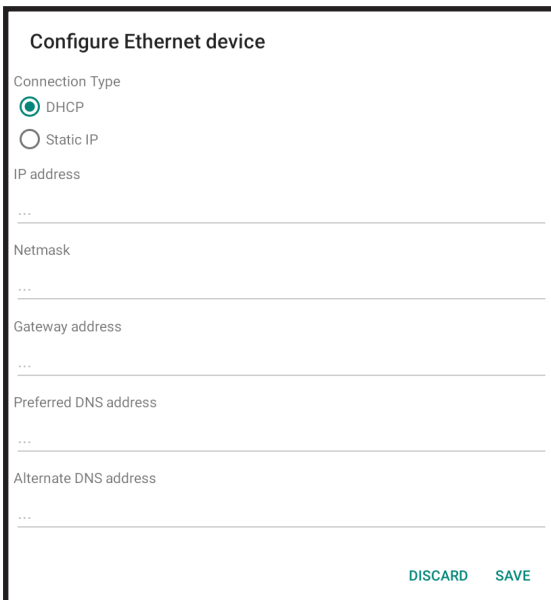

1. Select “Ethernet” from the settings list.
2. Select “Ethernet Configuration” for advanced ethernet networking options.
3. Static IP information can be entered if required.

*HandyTrac recommends DHCP IP address reservation on the network rather than manually entering static IP information.*

*Do not modify advanced ethernet options unless directed by your helpdesk or internal IT team.*

## Basic Maintenance and Upkeep Checks

- The HandyTrac system must be operated in an indoor environment and utilize a functioning Uninterruptible Power Supply (UPS). The HandyTrac system must be connected to the “Surge+Battery” power plug. For reference, a 600 VA UPS will provide ~2.5 hours of backup power. HandyTrac recommends powering off the system if you will be without power for an extended period of time and only use the system when absolutely necessary.
- The system must be installed and operated in a room reasonably free of dust and air particles; e.g. separate from a key cutting machine, woodwork, and other adverse activities.
- Temperature should not exceed 120° F or drop below 32° F.

### Daily:

- During standard operation, observe for any components or functionality concerns and contact HandyTrac Technical Services for assistance at 888-458-9994 if needed.
- Date and Time should be ticking and correct on Touchpad display.
- Ethernet cable should be connected at all times to the Touchpad. (If applicable)
- Barcode scanner should recognize badges and keytags.
- Touchscreen selections should be responsive and accurate.
- Fingerprint reader should illuminate and reliably recognize fingerprints.
- Electronic lock should automatically open the door when requesting and returning keys and securely lock back in place when the door is closed.

### As needed:

- Check cabinet square and door gap for proper door clearances.
- Check cabinet level and plumb for proper function and clearances.
- Inspect system for worn, damaged, or unserviceable key tags and replace as needed.
- Use a microfiber cloth to remove dust particles and oils from fingerprint reader.
- Review “Active Employee” list to ensure only authorized users are active and that badges are correctly assigned. Deactivate any staff that are no longer at the property.
- Update email report notifications and alerts to make sure necessary staff are notified of important key control information.
- Door alarm should trigger if a door is open when not signed in to the system.

### Semi-annually:

- Inspect connections to ethernet and power for disconnection, fraying, or other conditions that may cause connection failure or risk.
- Use canned air to remove dust particles from scanner.
- Audit the system for irregularities with any keytags (marked, damaged, missing) and replace as needed.
- Ensure cabinet backup keys are accessible to management staff in case of power outage. Along with a copy of the Key Map to find locations, these backup keys are the only way to access your unit keys in the event of a power outage.

# Have Questions?

HandyTrac technicians are available to answer your questions and guide you through anything you may need.

Email [service@handytrac.com](mailto:service@handytrac.com) or Call 888-458-9994 and choose option #3 for Technical Support.

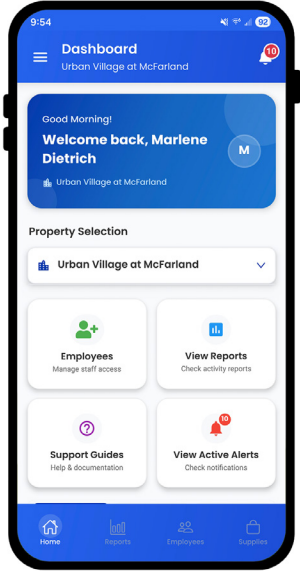

The HandyTrac app is available for both iOS and Android!

Search for "HandyTrac" in the App Store.

## HandyTrac Systems

510 Staghorn Ct.  
Alpharetta, GA 30004  
Phone: 678-990-2305

## Hours of Operation:

Monday - Friday  
8:30AM - 6:30PM Eastern  
24/7 Emergency Callbacks



The HandyTrac website and system is routinely updated with new features and improvements.

To find all of our guides, scan the QR code with your smartphone, or visit:

**<https://docs.handytrac.com>**